

Electronic-Database Information

Accession numbers and URLs for data in this article are as follows:

Online Mendelian Inheritance in Man (OMIM), <http://www.ncbi.nlm.nih.gov/Omim> (for *RP2* [MIM 312600], *RP3* [MIM 312610], *RP6* [MIM 312612], *RP15* [MIM 300029], and *RP24* [MIM 300155])

National Center for Biotechnology Information, <http://www.ncbi.nlm.nih.gov/>(for *RP2* sequence, accession number AJ007590)

References

- Aldred MA, Jay M, Wright AF (1994) X-linked retinitis pigmentosa. In: Wright AF, Jay B (eds) *Molecular genetics of inherited eye disorders*. Harwood Academic Publishers, Chur, Switzerland, pp 259–276
- Bird AC (1975) X-linked retinitis pigmentosa. *Br J Ophthalmol* 59:177–199
- Buraczynska M, Wu W, Fujita R, Buraczynska K, Phelps E, Andreasson S, Bennett J, et al (1997) Spectrum of mutations in the *RPGR* gene that are identified in 20% of families with X-linked retinitis pigmentosa. *Am J Hum Genet* 61:1287–1292
- Fujita R, Bingham E, Forsythe P, Segal M, Aita V, Navia BA, Dry K, et al (1996) A recombination outside the BB deletion refines the location of the X-linked retinitis pigmentosa locus *RP3*. *Am J Hum Genet* 59:152–158
- Fujita R, Buraczynska M, Gieser L, Wu W, Forsythe P, Abrahamson M, Jacobson SG, et al (1997) Analysis of the *RPGR* gene in 11 pedigrees with the retinitis pigmentosa type 3 genotype: paucity of mutations in the coding region but splice defects in two families. *Am J Hum Genet* 61:571–580
- Fujita R, Swaroop A (1996) *RPGR*: part one of the X-linked retinitis pigmentosa story. *Mol Vis* 2:4
- Gieser L, Fujita R, Goring HHH, Ott J, Hoffman DR, Cideciyan AV, Birch DG, et al (1998) A novel locus (*RP24*) for X-linked retinitis pigmentosa maps to Xq26-27. *Am J Hum Genet* 63:1439–1447
- MacDonald IM, Mah DY, Ho YK, Lewis RA, Seabra MC (1998) A practical diagnostic test for choroideremia. *Ophthalmology* 105:1637–1640
- McGuire RE, Sullivan LS, Blanton SH, Church MW, Heckelively JR, Daiger SP (1995) X-linked dominant cone-rod degeneration: linkage mapping of a new locus for retinitis pigmentosa (*RP15*) to Xp22.13-p22.11. *Am J Hum Genet* 57:87–94
- Meindl A, Dry K, Herrmann K, Manson F, Ciccociola A, Edgar A, Carvalho MRS, et al (1996) A gene (*RPGR*) with homology to the *RCC1* guanine nucleotide exchange factor is mutated in X-linked retinitis pigmentosa (*RP3*). *Nat Genet* 13:35–42
- Musarella MA, Anson-Cartwright L, Leal SM, Gilbert LD, Worton RG, Fishman GA, Ott J (1990) Multipoint linkage analysis and heterogeneity testing in 20 X-linked retinitis pigmentosa families. *Genomics* 8:286–296
- Ott J, Bhattacharya SS, Chen JD, Denton MJ, Donald J, Dubay C, Farrar GJ, et al (1990) Localizing multiple X-chromo-

- some-linked retinitis pigmentosa loci using multilocus homogeneity tests. *Proc Natl Acad Sci USA* 87:701–704
- Roepman R, van Duijnhoven G, Rosenberg T, Pinckers AJLG, Bleeker-Wagemakers LM, Bergen AAB, Post J, et al (1996) Positional cloning of the gene for X-linked retinitis pigmentosa 3: homology with the guanine-nucleotide-exchange factor *RCC1*. *Hum Mol Genet* 5:1035–1041
- Schwahn U, Lenzner S, Dong J, Feil S, Hinzmann B, van Duijnhoven G, Kirschner R, et al (1998) Positional cloning of the gene for X-linked retinitis pigmentosa 2. *Nat Genet* 19:327–332
- Teague PW, Aldred MA, Jay M, Dempster M, Harrison C, Carothers AD, Hardwick LJ, et al (1994) Heterogeneity analysis in 40 X-linked retinitis pigmentosa families. *Am J Hum Genet* 55:105–111
- Thiselton DL, Hampson RM, Nayudu M, Maldergem LV, Wolf ML, Saha BK, Bhattacharya SS, et al (1996) Mapping the *RP2* locus for X-linked retinitis pigmentosa on proximal Xp: a genetically defined 5-cM critical region and exclusion of candidate genes by physical mapping. *Genome Res* 6:1093–1102
- Tian G, Huang Y, Rommelaere H, Vandekerckhove J, Ampe C, Cowan NJ (1996) Pathways leading to correctly folded β -tubulin. *Cell* 86:287–296
- Yan D, Swain PK, Breuer D, Tucker RM, Wu W, Fujita R, Rehemtulla A, et al (1998) Biochemical characterization and subcellular localization of the mouse retinitis pigmentosa GTPase regulator (*mRpggr*). *J Biol Chem* 273:19656–19663

Address for correspondence and reprints: Dr. Anand Swaroop, Kellogg Eye Center, University of Michigan, 1000 Wall Street, Ann Arbor, MI 48105. E-mail: swaroop@umich.edu

*Drs. Mears and Yan, Ms. Gieser, and Ms. Chen contributed equally to this work.

[†]Present affiliation: Facultad de Medicina Humana, Universidad San Martin de Porres, Lima, Peru.

© 1999 by The American Society of Human Genetics. All rights reserved. 0002-9297/99/6403-0029\$02.00

Am. J. Hum. Genet. 64:900–904, 1999

A Fifth Locus for Bardet-Biedl Syndrome Maps to Chromosome 2q31

To the Editor:

Bardet-Biedl syndrome (BBS) is a rare autosomal recessive disorder with major clinical manifestations of retinal dystrophy, obesity, dysmorphic extremities, hypogonadism, and renal structural and functional abnormalities. It is distinguished from Laurence-Moon syndrome (MIM 245800), Biemond syndrome II (MIM 210350), and Alstrom syndrome (MIM 203800) by the absence of paraplegia, iris coloboma, and perceptive deafness, respectively. Four genetic loci for BBS have been mapped to distinct chromosomes, but the finding, in three recent population surveys, of several unlinked families with

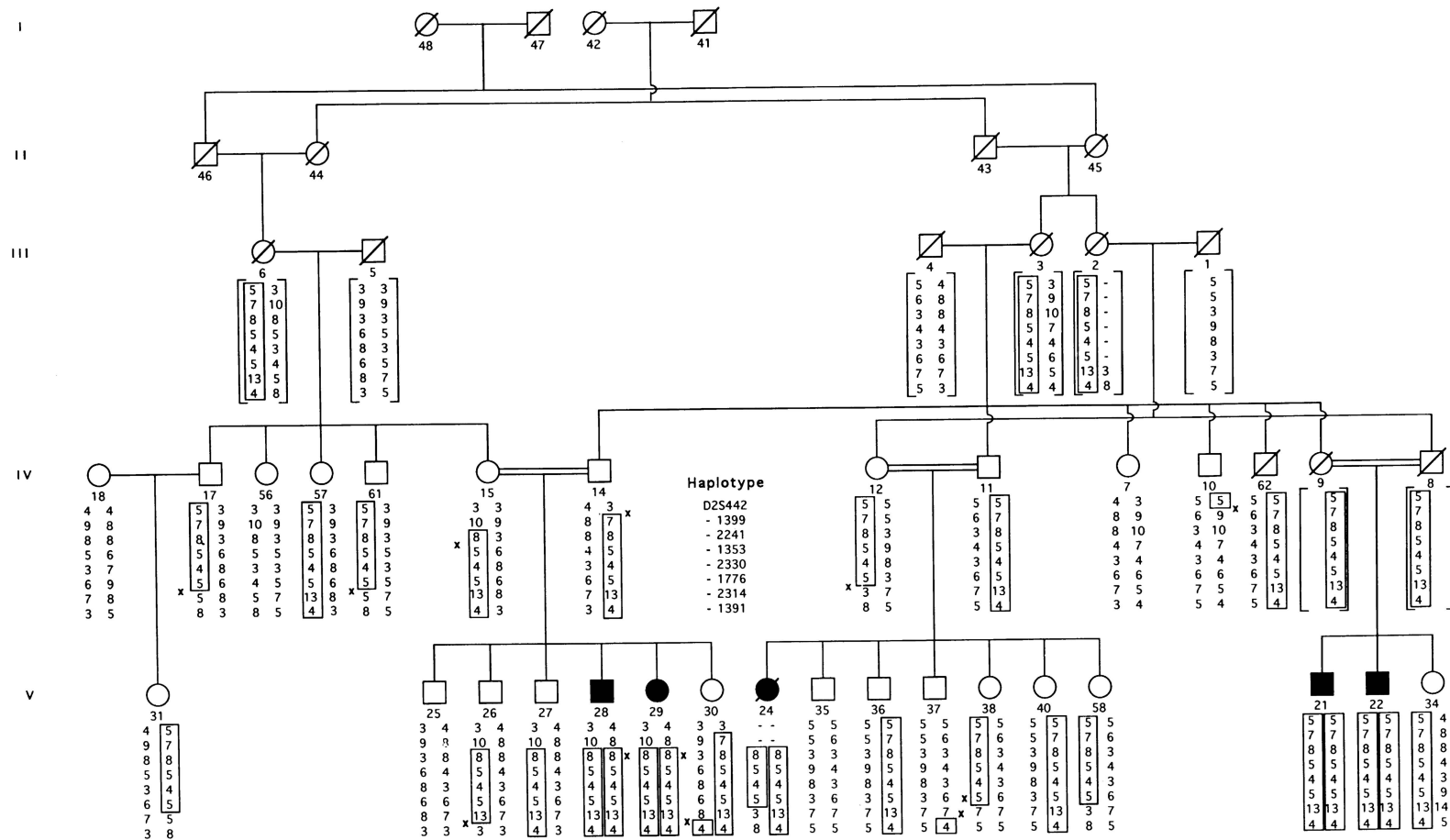

Figure 1 Cosegregation of BBS and an ancestral haplotype on chromosome 2q31 in kindred B9. Double marriage lines indicate consanguineous unions. Haplotypes were constructed manually and represent the minimal number of recombinations (x). The DNA sample from person 24 was extracted from a paraffin sample and often fails to amplify, but this person appears to be nonrecombinant for both parental chromosomes. The family members with BBS have inherited two copies of the ancestral haplotype (*boxed*) from a great-great-grandparent in generation I. The minimal region of homozygosity in relatives with BBS includes the markers pter-D2S124, D2S2330, D2S1776, and D2S335-pter.

Table 1**Clinical Manifestations of *BBS5* in a Newfoundland Kindred**

Patient (Sex/Age)	Body-Mass Index ^a (wt [kg]/ht [m] ²)	Polydactyly/Other ^b	Visual Acuity	Retinal Appearance	Small Penis
21 (M /31 years)	31.7	Absent/present	Light perception only	Advanced retinitis pigmentosa	Present
22 (M /25 years)	34.6	Absent/present	No light perception	Retinal degeneration	Not examined
24 (F /29 years)	49.4	Absent/present	No light perception	Atypical retinitis pigmentosa	Not applicable
28 (M /25 years)	40.4	Absent/present	Ability to count fingers	Retinitis pigmentosa	Present
29 (F /21 years)	42.8	Absent/present	20/300	Macular dystrophy	Not applicable

^a A value >27 is considered to indicate obesity (Nelson et al. 1994).

^b Other = brachydactyly and/or syndactyly.

BBS provides convincing evidence for at least a fifth BBS locus (Beales et al. 1997; Bruford et al. 1997; Woods et al. 1999).

BBS is a relatively rare disease, with an estimated world prevalence of 1/125,000–160,000 (Klein and Ammann 1969; Beales et al. 1997). However, two genetically isolated and distinct populations have been identified that provide a resource of large inbred families with BBS. One in 13,500 individuals has BBS in the Bedouin-Arab tribes of the Negev region of Israel, where the custom of consanguineous marriages is still practiced by >50% of the population and where two-thirds of these marriages are between first cousins (Farg and Teebi 1989; Sheffield et al. 1998). Half a world away, on the island portion of Newfoundland, the prevalence of BBS is 1/17,500 (Green et al. 1989). Matings between distant cousins in the Newfoundland population are frequent because of three historical factors: the geographic isolation of coastal fishing villages, the low rate of immigration to these communities, and the religious restrictions on mate selection between the Protestant English and Catholic Irish settlers (Bear et al. 1988). Three of the four BBS loci—*BBS2* (Kwitek-Black et al. 1993), *BBS3* (Sheffield et al. 1994), and *BBS4* (Carmi et al. 1995)—were identified by homozygosity mapping in individual Bedouin families. We have used a similar methodology to map the fifth genetic locus for BBS to chro-

mosome 2q31 in an inbred Newfoundland family of European ancestry.

A recently completed population-based survey of 17 BBS families from Newfoundland has identified six families in which the four known BBS loci were unambiguously excluded (Woods et al. 1999). Family B9, the largest of these kindreds, has five affected members who are the products of three consanguineous unions interrelated through two founding couples in generation I (fig. 1). The methods used in the clinic assessment of these patients have been described elsewhere (Green et al. 1989). The five patients with BBS surpass the minimal criteria of three major clinical manifestations for a BBS diagnosis, because of the presence of obesity, brachydactyly and/or syndactyly, retinal dystrophy, and male hypogenitalism, in the absence of paralysis, iris coloboma, or deafness (table 1). This pedigree met the requirements for the localization of *BBS5* by homozygosity mapping (Lander and Botstein 1987; Carmi et al. 1995). We anticipated that the affected individuals would be homozygous by descent for an ancestral haplotype inherited from one of the four pedigree founders.

A genomewide scan of pooled DNA samples was performed with microsatellite markers (Cooperative Human Linkage Consortium human screening set, Weber version 8; Research Genetics), as described elsewhere (Sheffield et al. 1994). Two control pools of DNA from

Table 2**Two-Point Linkage Analysis, for BBS and 2q31 Markers**

MARKER ^a	TWO-POINT LOD SCORE AT $\theta =$ ^b						Z_{max}	MAXIMUM θ
	.000	.010	.050	.100	.200	.300		
D2S442	-3.080	-2.205	-1.224	-.699	-.211	-.042	.009	.439
D2S1399	∞	-.416	0.982	1.321	1.174	.722	1.345	.122
D2S1353	5.675	5.556	5.075	4.463	3.214	1.970	5.675	.000
D2S1776	4.691	4.578	4.121	3.543	2.377	1.275	4.691	.000
D2S1391	∞	1.617	2.558	2.600	2.066	1.298	2.631	.078

NOTE.—A disease model of autosomal recessive inheritance, 100% penetrance, and a gene frequency of .008 were invoked.

^a Listed according to physical order (pter-qter) on chromosome 2q31.

^b Calculated by MLINK and ILINK from the FASTLINK package (version 4.0P).

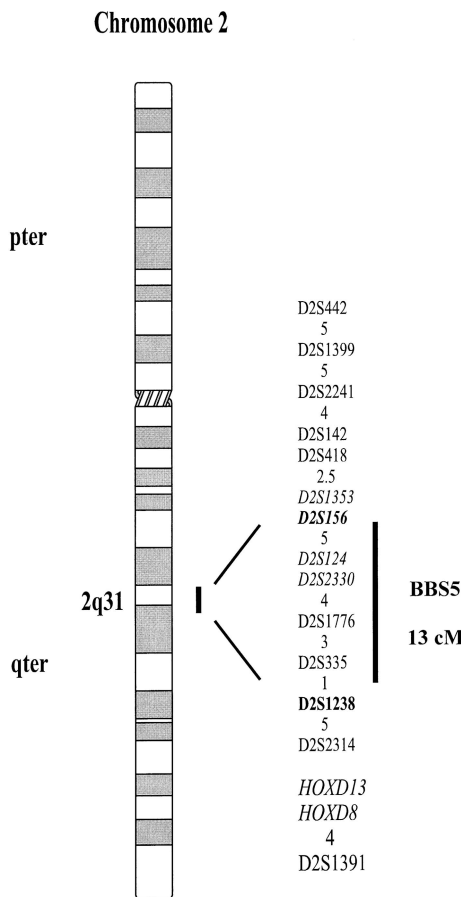

Figure 2 Critical region of *BBS5* on chromosome 2q31. Markers used to refine the position of *BBS5* are identified in terms of their “D” numbers. The marker order and distances were based on the Marshfield chromosome 2 (sex-averaged) linkage map (Center for Medical Genetics, Marshfield Medical Research Foundation) and the Chromosome 2 Workshop Consensus Map, 1996 (Genome Database). The *HOXD*-gene cluster lies downstream of the *BBS5* critical region.

4 living parents and 11 unaffected siblings, as well as a test pool of DNA from the 4 surviving patients, were amplified. Of the first 322 markers successfully amplified, 6 showed a reduction in the number of alleles (allele shift) in the test pool, compared with the control pools. Subsequent genotyping of these markers on the extended family proved that they were not linked to *BBS*, resulting in a false-positive rate of 1.9%. However, the 323d marker, D2S1353, gave a 4:1 allele shift, from the control pools to the test pool. Genotyping of D2S1353 on the pedigree showed it to be exclusively homozygous in patients with *BBS*. Two-point analysis showed significant linkage between *BBS* and D2S1353, with no recombination (maximum LOD score [Z_{max}] 5.675; recombination fraction [θ] 0). Genotyping of markers flanking D2S1353 confirmed linkage to 2q31 (table 2)

and showed an ancestral haplotype that is homozygous by descent in all affected relatives (fig. 1).

The initial assignment of the *BBS* phenotype in close proximity to the *HOXD*-gene cluster on chromosome 2q31 suggested that these nine homeobox genes of the *Drosophila antennapedia* class and other closely located genes (*EVX2* and *DLX1/DLX2*) that are involved in patterning of the embryo are candidate genes for *BBS*. Recent findings that duplication of the *HOXD13* gene causes synpolydactyly (Akarsu et al. 1996) focused our attention on it as the most promising gene candidate, given that syndactyly and/or polydactyly are congenital manifestations of *BBS*. However, refined mapping of two key recombinant ancestral chromosomes in patients 15 and 12 placed *BBS5* within the 13-cM interval D2S156–D2S1238 (fig. 2), several centimorgans upstream from the *HOXD13* gene that is positioned at the proximal end of the *HOXD*-gene cluster (Spurr et al. 1996). Refined mapping of the recombinant ancestral chromosome excludes all genes within the *HOXD*-gene cluster as being candidate genes for *BBS5*.

Acknowledgments

We thank the family for their participation in this study. Financial support for this work came from the Kidney Foundation of Canada and the Medical Research Council of Canada. T.-L.Y. and M.O.W. are recipients of Graduate Fellowships from the Faculty of Medicine at Memorial University. J.S.G is a recipient of a grant from the Canadian Genetic Diseases Network.

TERRY-LYNN YOUNG,¹ LYNETTE PENNEY,¹
 MICHAEL O. WOODS,¹ PATRICK S. PARFREY,¹
 JANE S. GREEN,¹ DONNA HEFFERTON,¹ AND
 WILLIAM S. DAVIDSON²

¹Faculty of Medicine and ²Department of Biochemistry, Memorial University, St. John’s, Newfoundland

Electronic-Database Information

Accession numbers and URLs for data in this article are as follows:

- Cooperative Human Linkage Consortium, <http://www.chlc.org/HomePage.html> (for microsatellite markers)
- Genome Database, <http://gdbwww.gdb.org> (for marker order and distance)
- Center for Medical Genetics, Marshfield Medical Research Foundation, <http://www.marshmed.org/genetics> (for marker order and distance)
- Online Mendelian Inheritance in Man (OMIM), <http://www.ncbi.nlm.nih.gov/omim> (for Laurence-Moon syndrome [MIM 245800], Biemond syndrome II [MIM 210350], and Alstrom syndrome [MIM 203800])

References

- Akarsu AN, Stoilov I, Yilmaz E, Sayli BS, Sarfarazi M (1996) Genomic structure of HOXD13 gene: a nine polyalanine duplication causes synpolydactyly in two unrelated families. *Hum Mol Genet* 5:945–952
- Beales PL, Warner AM, Hitman GA, Thakker R, Flintner FA (1997) Bardet-Biedl syndrome: a molecular and phenotypic study of 18 families. *J Med Genet* 34:92–98
- Bear JC, Nemecek TF, Kennedy JC, Marshall WH, Power AA, Kolonel VM, Burke GB (1988) Inbreeding in outport Newfoundland. *Am J Med Genet* 29:649–660
- Bruford EA, Riise R, Teague PW, Porter K, Thomson KL, Moore AT, Jay M, et al (1997) Linkage mapping in 29 Bardet-Biedl syndrome families confirms loci in chromosomal regions 11q13, 15q22.3–q23, and 16q21. *Genomics* 41:93–99
- Carmi R, Rokhlina T, Kwitek-Black AE, Elbedour K, Nishimura D, Stone EM, Sheffield VC (1995) Use of a DNA pooling strategy to identify a human obesity syndrome locus on chromosome 15. *Hum Mol Genet* 4:9–13
- Farag TI, Teebi AS (1989) High incidence of Bardet-Biedl syndrome among the Bedouin. *Clin Genet* 36:463–465
- Green JS, Parfrey PS, Harnett JD, Farid NR, Cramer BC, Johnson G, Heath O, et al (1989) The cardinal manifestations of Bardet-Biedl syndrome, a form of Laurence-Moon-Biedl syndrome. *N Engl J Med* 321:1002–1009
- Klein D, Ammann F (1969) The syndrome of Lawrence-Moon-Bardet-Biedl and allied diseases in Switzerland. *J Neurol Sci* 9:479–513
- Kwitek-Black AE, Carmi R, Duyk GM, Buetow KH, Elbedour K, Parvari R, Yandava C, et al (1993) Linkage of Bardet-Biedl syndrome to chromosome 16q and evidence for non-allelic genetic heterogeneity. *Nat Genet* 5:392–396
- Lander ES, Botstein D (1987) Homozygosity mapping: a way to map human recessive traits with the DNA of inbred children. *Science* 236:1567–1570
- Nelson JK, Moxness KE, Jensen M, Gastmean C (1994) Mayo Clinic diet manual of nutrition practice, 7th ed. CW Mosby, St Louis, pp 186, 657
- Sheffield VS, Carmi R, Kwitek-Black A, Rokhlina T, Nishimura D, Duyk GM, Elbedour K, et al (1994) Identification of a Bardet-Biedl syndrome locus on chromosome 3 and evaluation of an efficient approach to homozygosity mapping. *Hum Mol Genet* 3:1331–1335
- Sheffield VS, Stone EM, Carmi R (1998) Use of isolated inbred human populations for identification of disease genes. *Trends Genet* 14:391–396
- Spurr NK, Bashir R, Bushby K, Cox A, Cox S, Hildebrandt F, Hill N, et al (1996) Report and abstracts of the Fourth International Workshop on Human Chromosome 2 Mapping 1996. *Cytogenet Cell Genet* 73:255–273
- Woods MO, Young TL, Parfrey PS, Hefferton D, Green JS, Davidson WS (1999) Genetic heterogeneity of Bardet-Biedl syndrome in a distinct Canadian population: evidence for a fifth locus. *Genomics* 55:2–9

Address for correspondence and reprints: Dr. Terry-Lynn Young, Department of Biochemistry, Memorial University of Newfoundland, St. John's, Newfoundland, Canada, A1B 3X9. E-mail: tlyoung@morgan.ucs.mun.ca

© 1999 by The American Society of Human Genetics. All rights reserved.
0002-9297/99/6403-0030\$02.00

Am. J. Hum. Genet. 64:904–908, 1999

Autosomal Dominant (Beukes) Premature Degenerative Osteoarthropathy of the Hip Joint Maps to an 11-cM Region on Chromosome 4q35

To the Editor:

We have previously reported the clinical and radiographic features of affected individuals from a large kindred who have an autosomal dominant form of bilateral dysplasia of the hip joints with severe secondary osteoarthrosis (Cilliers and Beighton 1990). This family came to the attention of one of us (H.C.) because of the number of patients with the family name, Beukes, who presented to the Department of Orthopaedic Surgery, University of Orange Free State, South Africa, for prosthetic hip-joint replacement as a consequence of bilateral premature degenerative osteoarthropathy. Genealogical studies subsequently revealed that all the affected individuals were members of an extended family that could be traced back to a single Dutch immigrant to South Africa who arrived in 1685 (Cilliers and Beighton 1990). Our continued investigation of this family has now traced 55 individuals in eight generations who, on the basis of either their medical histories or clinical and radiographic presentation of the disorder, appear to have inherited the disorder. The disorder clearly has an autosomal dominant mode of inheritance, but there is some evidence of nonpenetrance in that apparently unaffected individuals have had affected offspring. The clinical and radiographic manifestations have been described in detail elsewhere (Cilliers and Beighton 1990). In brief, the presenting symptom is hip-joint discomfort, which usually develops during childhood at age <2 years but may develop either later in childhood or, as in one instance, as late as the age of 35 years. After onset of symptoms, the hip joints deteriorate progressively, gait is disturbed, and, by early adulthood, affected persons are crippled by degenerative arthropathy. The earliest radiological changes are broadening of the femoral necks, late appearance of the secondary ossification centers of the femoral head, and an irregular appearance of the proximal epiphyseal line of the femur. By mid childhood, the femoral heads are flat (coxa plana), with broadening of the femoral necks, adaptation of the acetabulum to the mal-